

The 20 range architectural hardware is manufactured in our own factory located in Hoddesdon Hertfordshire and unlike other hardware factors we are unique in offering a product in which we are able to control the quality and finish to a consistently high standard throughout the range. Our lever handle range uses the severe duty SL deep bearing system and locked on to a concealed fixing rose, with back to back fixings together with spindle fixing will out perform most other products.

20.2011.SS

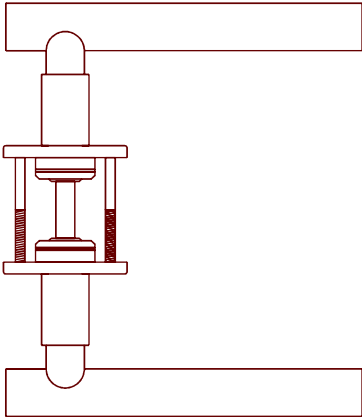

20.2011.SS



see details on page 2

trapex hardware ltd : 20 range

20mm dia	Code/dia/Finish	16mm dia
	2000 Finish: SS/PS/SA/PB	
	2001 Finish: SS/PS/SA/PB	
	2008 Finish: SS/PS	
	2009 Finish: SS/PS	
	2010 Finish: SS/PS/SA/PB	
	2011 Finish: SS/PS	
	2012 Finish: SS/PS	
	2017 Finish: SS/PS	

The 20 Range of Architectural Hardware is manufactured in our own premises located in Hoddesdon Hertfordshire and unlike other hardware suppliers we are unique in offering a product in which we are able to control the quality and finish to a consistently high standard throughout the range. We continue to invest in the latest machinery.

The material used is solid stainless steel which gives the ultimate feel, weight and quality. Our lever handle range uses the severe duty SL deep bearing system with locked threaded connection to a concealed fixing rose, with back to back fixings together with spindle fixing.

Specification example :

2000.20.SS 1 Pair 20mm dia Satin Stainless Steel Safety Lever handles on 52mm dia SL bearing roses c/w spindle and fixings.

